



# GOUPIL G4-11

## High Tip Waste Body

100% Electric

Zero Emissions

Road Homologated

**BRADSHAW**  
ELECTRIC • VEHICLES



## OVERVIEW

The Goupil G4 is an all electric, zero emission light commercial utility vehicle. Road homologated to N1, the G4 is an ideal solution for a multitude of road applications both, public and private. The G4 has an impressive payload of up to 1200kg on the lithium Ion version.

## ENVIRONMENTALLY FRIENDLY

100% Electric, Zero Emissions compliant for Low and Ultra Low Emission Zone within towns and cities. Silent operation enables night-time and early morning use.

## ROAD LEGAL

The Goupil G4's are homologated to N1 and can be road registered (zero-rated) for use on public highways.

## PERFORMANCE

The Curtis 48 volt controller gives the G4 a top speed of up to 31mph and handles gradients up to 18% laden and 30% unladen.

## FLEXIBLE

Over 12 standard body options and with the ability to specify left hand or right hand drive, lead acid or lithium ion batteries, gives great versatility when configuring a G4 to match specific applications.

In addition to the vehicles robust and versatile structure means the chassis can support customised equipment, ie refrigerated body, demountable street cleansing and gritting equipment.

## ROBUST

The robust chassis is constructed from S345 steel, cataphoresis coated, robot welded and powder coated.

## WARRANTY

Truck: 2 years parts and labour warranty  
Battery

Lead Acid: 3 years parts and labour warranty

Lithium Ion: 5 years parts and labour warranty



Lead Acid / Lithium  
100% Electric  
Zero-Emissions



N1 Type Approval



Range 47-106 miles



Left hand /  
Right hand drive



Payload up to 1200kg



# STANDARD BODY OPTIONS

---



**G4-01**  
CHASSIS CAB



**G4-02**  
PICK-UP



**G4-03**  
PICK-UP CAGE BODY



**G4-04**  
PICK-UP CAGE TIPPER



**G4-05**  
PICK-UP PVC COVER



**G4-06**  
VAN BODY



**G4-07**  
COMBINED PICK-UP WITH  
200L PRESSURE WASHER



**G4-08**  
COMBINED PICK-UP WITH TOOLBOX



**G4-09**  
COMBINED PICK-UP CAGE BODY  
WITH LEAF COLLECTOR



**G4-10**  
PICK-UP WITH 500L PRESSURE WASHER



**G4-11**  
HIGH TIP WASTE BODY

# FEATURES

## 355 Steel Chassis

- Cataphoresis coated, robot welded, powder coating including gap sealing

## High Tip Waste Body

- Hydraulic high tipping steel body
- Tipping height 1500mm
- Cab mounted tipper controller
- Half dropdown loading door to both sides
- Body prop
- Drain tap to facilitate cleaning

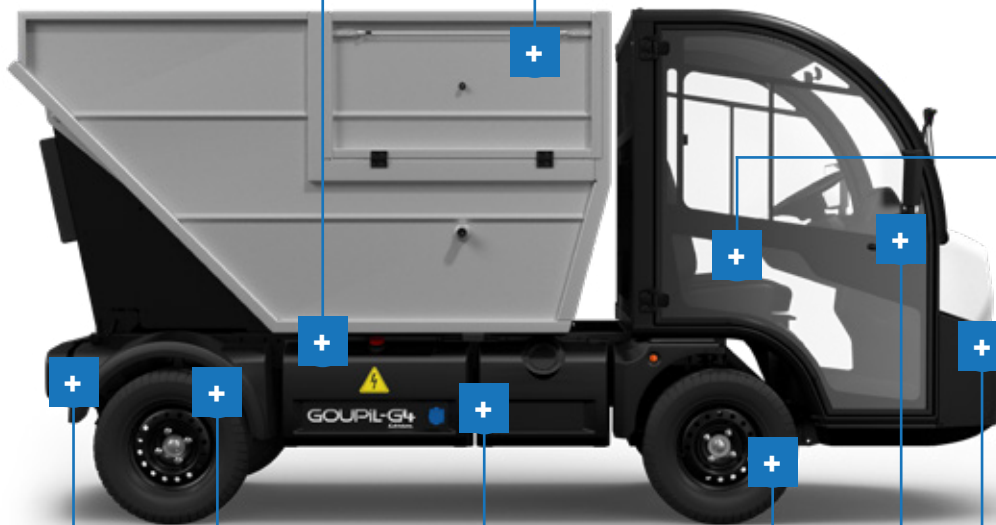

## Tow Hitch (Optional)

- Tow hitch and trailer socket

## Battery

- 100% Electric
- Zero Emission
- Lead Acid or Lithium

## Braking

- Electronic regenerative braking
- Dual circuit hydraulic brake system with a braking compensator controlled by the load
- Front: disk brakes
- Rear: drum brakes

## Full Road Lighting

- In accordance with N1
- Headlights
- Side lights
- Rear and brake light
- Indicators
- Hazard warning lights
- Reverse light
- Rear fog light
- LED running lights

## Suspension

- Front-wheels: McPherson with helical springs and hydraulic shock absorber
- Rear-wheels: leaf-spring with hydraulic shock absorber



## High-definition LCD colour display

- High-definition LCD colour display including
- Battery discharge indicator
- Digital speedometer
- Odometer
- Low level warning lights
- Dash mounted lamp to indicate when park brake is applied

# DIMENSIONS AND PERFORMANCE

## BATTERY

Battery Type		Lead Acid		Lithium-Ion	
Battery Size	(kWh)	11.5	15.4	9.0	14.0
Homologation		N1	N1	N1	N1

## WEIGHTS

GVM   Gross Vehicle Weight	(kg)	2100	2100	2100	2100
Kerb weight	(kg)	1258	1330	985	1029
Payload capacity	(kg)	842	770	1115	1071
Gross payload capacity (includes 75kg allowance for operator)	(kg)	767	695	1040	996
Maximum weight of the combination (GCW)	(kg)	3500	3500	3500	3500
Tow load capacity - Braked (For road use) <sup>1</sup>	(kg)	1400	1400	1400	1400
Tow load capacity - unbraked (For road use) <sup>1</sup>	(kg)	628	665	493	515

## BATTERIES AND CHARGER

Battery voltage / nominal capacity	(v) / (a)	48 / 240	48 / 320	48 / 190	48 / 290
Recharge time	(hours)	8h 30	9h 45	4h 15	6h 30
Charger	(v) / (a)	48 / 30	48 / 60	48 / 60	
Supply		240v single phase		240v single phase	
Current draw	(a)	12		12	
Auxiliary battery	(v) / (a)	12 / 45		12 / 45	

## PERFORMANCE

Maximum torque	(Nm)	57		57	
Nominal power	(kW)	10		10	
Range (according to WLTP cycle) <sup>2</sup>	(miles)	27 - 40	37 - 49	37 - 46	55 - 68
Two factory speed settings: High speed / Low speed	(mph)	31 / 6.5	31 / 6.5	31 / 6.5	31 / 6.5
Maximum gradient - unladen / laden	(%)	30 / 15	30 / 15	30 / 15	
Maximum gradient - with trailer	(%)	12		12	
Approach angle	(°)	20		20	
External turning radius wall to wall	(mm)	4383		4383	
External turning radius kerb to kerb	(mm)	3900		3900	

## HIGH TIP WASTE BODY SPECIFICATION

Useful capacity	(m <sup>3</sup> )	2.27			
Tipping angle	(°)	86			
Height collector tipped	(mm)	3665			
Dumping height	(mm)	1420			
Height of the dropdown door threshold	(mm)	1380			
Width of the dropdown door	(mm)	960			
Hydraulic unit lifting capacity	(kg)	820			

<sup>1</sup> Tow hitch available as an optional extra

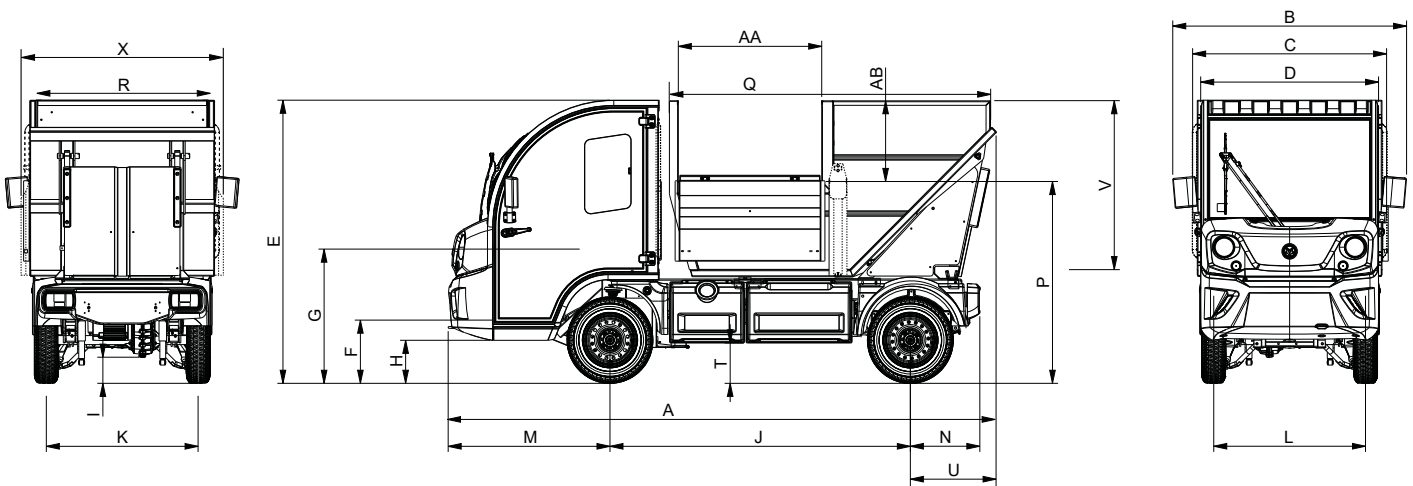

## DIMENSIONS (MM)

A	B	C	D	E	F	G	H	I	J	K	L	M	N	P	Q	R	T	U	V	X	AA	AB
3688	1574	1305	1200	1893	423	897	288	175	2022	1045	1045	1089	577	1349	2159	1167	282	577	1129	1350	960	540

# STANDARD EQUIPMENT & OPTIONS

	MODEL	G4-11
CONFIGURATION	100% electric light commercial road vehicle	•
	Road homologated	N1
	Power unit: 48 volt AC controller	•
	Rear drive axle with limited slip differential	•
BATTERIES & ACCESSORIES	11.5 kWh 48v 240Ah lead acid battery	○
	15.4 kWh 48v 320Ah lead acid battery	○
	9.0 kWh 48v 190Ah lithium ion battery	○
	14.0 kWh 48v 300Ah lithium ion battery	○
	Auxiliary 45Ah battery to run 12 volt system. Battery charged during operation via DC/DC converter	•
	Auxiliary battery upgrade includes <ul style="list-style-type: none"> <li>• 12 volt connecting plug / socket to power additional auxiliary equipment</li> <li>• 60Ah battery in place of standard Ah auxiliary battery</li> <li>• Additional 48v - 12v 300W DC/DC converter to charge upgraded battery during operation</li> </ul>	○
BRAKING SYSTEMS	Dual circuit hydraulic brake system	•
	Front: disk brakes	•
	Rear: drum brakes	•
	Electronic regenerative braking under deceleration with proportioning electric braking system	•
	Hand operated park brake with torque limiting sensor	•
SUSPENSION & STEERING	Front-wheels: McPherson with helical springs and hydraulic shock absorber	•
	Rear-wheels: McPherson with helical springs and hydraulic shock absorber	•
	Rack and pinion steering	•
	Power assisted steering	•
	Right hand drive	•
	Left hand drive	○
LIGHTING & ACCESSORIES	Full road lighting in accordance with N1 homologation <ul style="list-style-type: none"> <li>• Headlights, side, rear &amp; brake lights, indicators, hazard warning lights, reverse light, rear fog light, LED daytime running lights</li> </ul>	•
	Amber flashing beacon mounted on cab	•
	LED random flashing amber warning lights	○
	Rear mounted 12 volt working light	○
CONTROLS & AUDIBLE WARNINGS	High / low speed switch, 2 factory set speed settings between 6.5 and 31mph	•
	Safety seat cut out. Vehicle will not operate unless driver is seated	•
	Emergency isolator	•
	Horn	•
	Automatic audible warning in reverse	•
	Forward audible warning via dash mounted switch (bell)	○
	Automatic audible warning in forward (white noise)	○
	Progressive audible warning system in forward AVAS Acoustic Vehicle Alerting System compliant to UNECE R138	•
EQUIPMENT & FEATURES	High-definition LCD colour display	•
	Battery discharge indicator	•
	Digital speedometer	•
	Odometer	•
	Low level warning lights	•
	Dash mounted lamp to indicate when park brake is applied	•
	12 volt auxiliary socket	•
	Ignition key and steering lock	•
	2 stage deep discharge protection <ul style="list-style-type: none"> <li>• Traction battery low level indicator,</li> <li>• Automatic low speed cutback to prevent over discharge</li> </ul>	•

	MODEL	G4-11
TYRES	Tubeless radial 155R13C 90N	•
	Anti puncture treatment	○
	Spare wheel (155R13C 90C) c/w jack & brace	○
	Winter tyres 155/80R13 79Q	○
	Michelin tyre pressure management system	○
TOW HITCH	50mm ball with 7 pin socket	•
	Combined 25mm pin single jaw tow hitch & 50mm ball with 7 pin socket	○
CAB	Polypropylene bumpers	•
	Rear cab window	•
	Central locking	•
	Sliding door windows	•
	ABS glass front and rear screens	•
	Electric front wiper and screen wash	•
	Electric heated front windscreen	•
	Electric heater (700 watt)	•
	Diesel heater	○
	Electric heated drivers seat	○
	Interior and exterior mirrors	•
	Interior light	•
	Glove compartment	•
	MP3 radio with Bluetooth connectivity	•
	USB socket	○
	Rear mounted camera with display screen	○
Cab storage set to include bottle holder and central storage tray	○	
SEATING	Adjustable driver and passenger seats	•
	Padded adjustable headrests	•
	Three-point inertia seat belts	•
BODY	High Tip Waste Body	•
	Hydraulic high tipping steel body	•
	Cab mounted tipper controller	•
	Half dropdown loading door to both sides	•
	Body prop	•
	Drain tap to facilitate cleaning	•
	Roll out canvas cover over waste body	○
MISC	1kg dry powder fire extinguisher	○
	Road registered for category N1	○
COLOUR	Chassis: Black, S345 steel, cataphoresis coated, robot welded, powder coating and gap sealing	•
	Cab roof and bonnet: White	•
	Custom colour. Chassis black. Cab roof and bonnet to customer's single colour specification. RAL number to be supplied at time of order	○
	Custom colour. Chassis black. Vinyl wrap cab roof and bonnet to customer's specification	○
	Class 2 hi-visibility reflective band kit	○





## **BRADSHAW ELECTRIC VEHICLES**

New Lane

Stibbington

Peterborough

PE8 6LW

[enquiries@bradshawev.com](mailto:enquiries@bradshawev.com)

[www.bradshawEV.com](http://www.bradshawEV.com)

01780 782 621

All data and specifications are in accordance with information available at the time of publication and are subject to change without notice.

Some of the vehicles shown may be fitted with optional equipment or accessories that are available at extra cost.

This brochure supersedes all previous publications.  
Issue: April 2022

**BRADSHAW**  
ELECTRIC • VEHICLES