



GOUPIL G4-09

Combined Pick-Up with Electric Leaf Collector

100% Electric

Zero Emissions

Road Homologated

BRADSHAW
ELECTRIC • VEHICLES



OVERVIEW

The Goupil G4 is an all electric, zero emission light commercial utility vehicle. Road homologated to N1, the G4 is an ideal solution for a multitude of road applications both, public and private. The G4 has an impressive payload of up to 1200kg on the lithium Ion version.

ENVIRONMENTALLY FRIENDLY

100% Electric, Zero Emissions compliant for Low and Ultra Low Emission Zone within towns and cities. Silent operation enables night-time and early morning use.

ROAD LEGAL

The Goupil G4's are homologated to N1 and can be road registered (zero-rated) for use on public highways.

PERFORMANCE

The Curtis 48 volt controller gives the G4 a top speed of up to 31mph and handles gradients up to 18% laden and 30% unladen.

FLEXIBLE

Over 12 standard body options and with the ability to specify left hand or right hand drive, lead acid or lithium ion batteries, gives great versatility when configuring a G4 to match specific applications.

In addition to the vehicles robust and versatile structure means the chassis can support customised equipment, ie refrigerated body, demountable street cleansing and gritting equipment.

ROBUST

The robust chassis is constructed from S345 steel, cataphoresis coated, robot welded and powder coated.

WARRANTY

Truck: 2 years parts and labour warranty

Battery

Lead Acid: 3 years parts and labour warranty

Lithium Ion: 5 years parts and labour warranty



Lead Acid / Lithium
100% Electric
Zero-Emissions



N1 Type Approval



Range 47-106 miles



Left hand /
Right hand drive



Payload up to 1200kg

STANDARD BODY OPTIONS



G4-01
CHASSIS CAB



G4-02
PICK-UP



G4-03
PICK-UP CAGE BODY



G4-04
PICK-UP CAGE TIPPER



G4-05
PICK-UP PVC COVER



G4-06
VAN BODY



G4-07
COMBINED PICK-UP WITH
200L PRESSURE WASHER



G4-08
COMBINED PICK-UP WITH TOOLBOX



G4-09
COMBINED PICK-UP CAGE BODY
WITH LEAF COLLECTOR



G4-10
PICK-UP WITH 500L PRESSURE WASHER



G4-11
HIGH TIP WASTE BODY

FEATURES

355 Steel Chassis

- Cataphoresis coated, robot welded, powder coating including gap sealing

Combined Chassis Pick-Up with Electric Leaf Collector

- 100% electric
- 48 volt, 2200rpm 2 KW motor
- 5m extra flexible and anti-abrasive hose 180mm od
- Sound level (3m): 78dB
- Capture netting fitted to rear cage body
- Operator harness

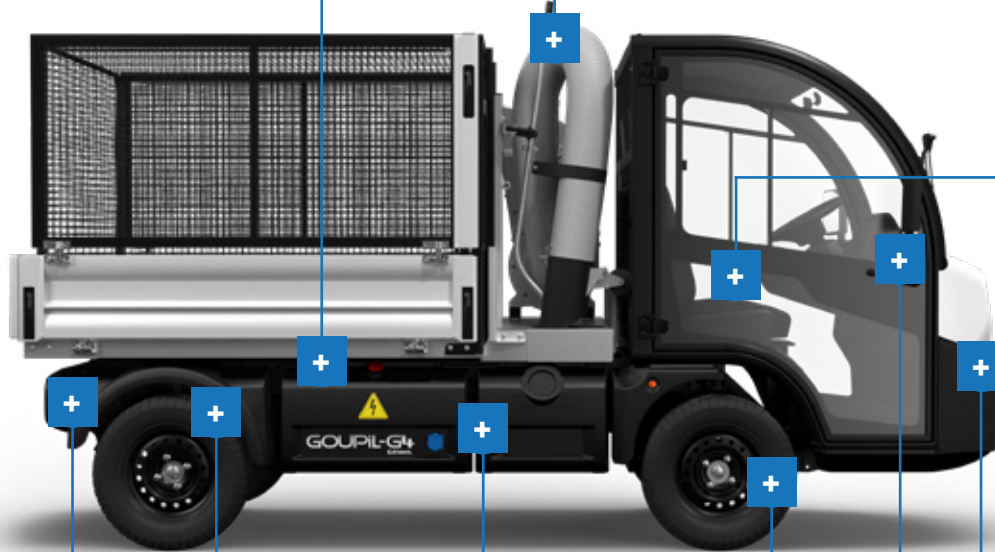

Central Locking

Tow Hitch (Optional)

- Tow hitch and trailer socket

Battery

- 100% Electric
- Zero Emission
- Lead Acid or Lithium

Braking

- Electronic regenerative braking
- Dual circuit hydraulic brake system with a braking compensator controlled by the load
- Front: disk brakes
- Rear: drum brakes

Full Road Lighting

- In accordance with N1
- Headlights
- Side lights
- Rear and brake light
- Indicators
- Hazard warning lights
- Reverse light
- Rear fog light
- LED running lights

Suspension

- Front-wheels: McPherson with helical springs and hydraulic shock absorber
- Rear-wheels: leaf-spring with hydraulic shock absorber



High-definition LCD colour display

- High-definition LCD colour display including
- Battery discharge indicator
- Digital speedometer
- Odometer
- Low level warning lights
- Dash mounted lamp to indicate when park brake is applied

DIMENSIONS AND PERFORMANCE

BATTERY

Battery Type		Lead Acid		Lithium-Ion	
Battery Size	(kWh)	11.5	15.4	9.0	14.0
Homologation		N1	N1	N1	N1

WEIGHTS

GVM Gross Vehicle Weight	(kg)	2100	2100	2100	2100
Kerb weight	(kg)	1458	1532	1187	1231
Payload capacity	(kg)	642	568	913	869
Gross payload capacity (includes 75kg allowance for operator)	(kg)	567	493	838	794
Volume	(m ³)	2.15	2.15	2.15	2.15
Maximum weight of the combination (GCW)	(kg)	3500	3500	3500	3500
Tow load capacity - Braked (For road use) ¹	(kg)	1400	1400	1400	1400
Tow load capacity - unbraked (For road use) ¹	(kg)	594	631	459	481

BATTERIES AND CHARGER

Battery voltage / nominal capacity	(v) / (a)	48 / 240	48 / 320	48 / 190	48 / 290
Recharge time	(hours)	8h 30	9h 45	4h 15	6h 30
Charger	(v) / (a)	48 / 30	48 / 60	48 / 60	
Supply		240v single phase		240v single phase	
Current draw	(a)	12		12	
Auxiliary battery	(v) / (a)	12 / 45		12 / 45	

PERFORMANCE

Maximum torque	(Nm)	57		57	
Nominal power	(kW)	10		10	
Range (according to WLTP cycle) ²	(miles)	27 - 40	37 - 49	37 - 46	55 - 68
Two factory speed settings: High speed / Low speed	(mph)	31 / 6.5		31 / 6.5	
Maximum gradient - unladen / laden	(%)	30 / 15		30 / 15	
Maximum gradient - with trailer	(%)	12		12	
Approach angle	(°)	20		20	
External turning radius wall to wall	(mm)	4383		4383	
External turning radius kerb to kerb	(mm)	3900		3900	

PRESSURE WASHER SPECIFICATION

Motor	(v)	48
	(Kw)	2
	(rpm)	2200
Sound level (3m)	(dB)	78

¹Tow hitch available as an optional extra

²Use of the electric leaf collector will effect the rated autonomy

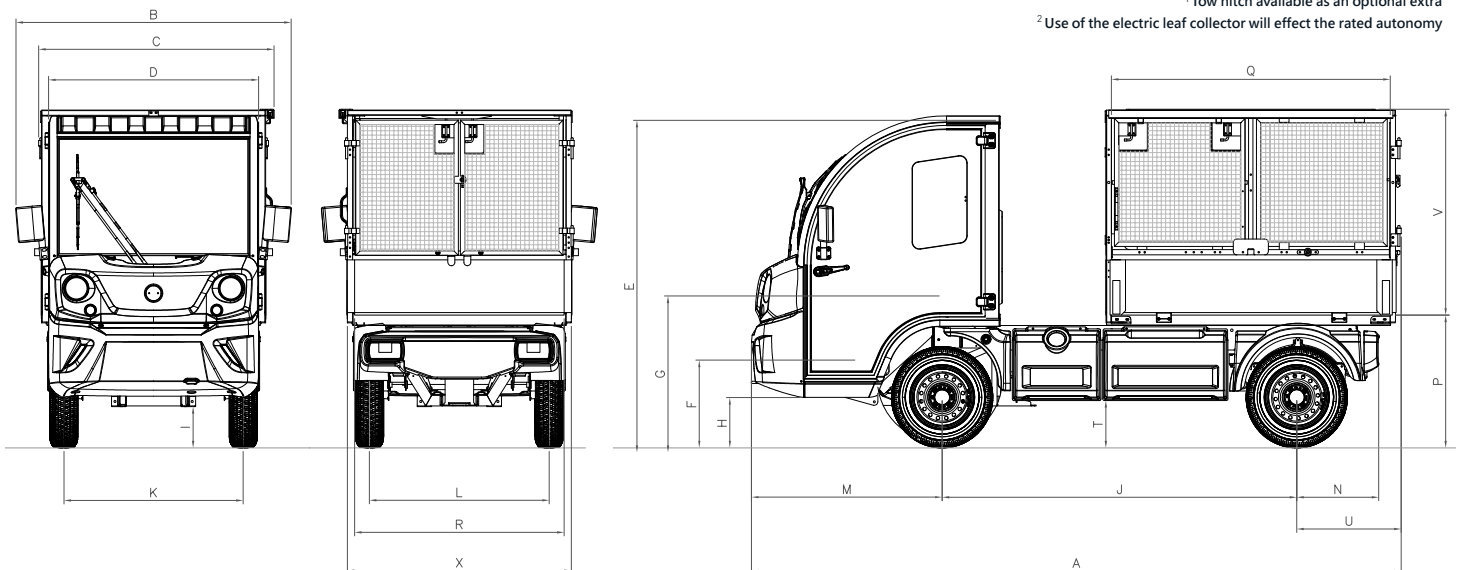

DIMENSIONS (MM)

A	B	C	D	E	F	G	H	I	J	K	L	M	N	P ¹	Q	R	T	U	V	X
3675	1574	1305	1200	1893	423	897	288	175	2022	1045	1045	1089	468	787	1597	1222	282	564	1106	1298

¹The addition of optional hydraulic tipping complete with aluminium floor increases platform height by 110mm

STANDARD EQUIPMENT & OPTIONS

	MODEL	G4-09
CONFIGURATION	100% electric light commercial road vehicle	•
	Road homologated	N1
	Power unit: 48 volt AC controller	•
	Rear drive axle with limited slip differential	•
BATTERIES & ACCESSORIES	11.5 kWh 48v 240Ah lead acid battery	○
	15.4 kWh 48v 320Ah lead acid battery	○
	9.0 kWh 48v 190Ah lithium ion battery	○
	14.0 kWh 48v 300Ah lithium ion battery	○
	Auxiliary 45Ah battery to run 12 volt system. Battery charged during operation via DC/DC converter	•
	Auxiliary battery upgrade includes <ul style="list-style-type: none"> • 12 volt connecting plug / socket to power additional auxiliary equipment • 60Ah battery in place of standard Ah auxiliary battery • Additional 48v - 12v 300W DC/DC converter to charge upgraded battery during operation 	○
BRAKING SYSTEMS	Dual circuit hydraulic brake system	•
	Front: disk brakes	•
	Rear: drum brakes	•
	Electronic regenerative braking under deceleration with proportioning electric braking system	•
	Hand operated park brake with torque limiting sensor	•
SUSPENSION & STEERING	Front-wheels: McPherson with helical springs and hydraulic shock absorber	•
	Rear-wheels: McPherson with helical springs and hydraulic shock absorber	•
	Rack and pinion steering	•
	Power assisted steering	•
	Right hand drive	•
	Left hand drive	○
LIGHTING & ACCESSORIES	Full road lighting in accordance with N1 homologation <ul style="list-style-type: none"> • Headlights, side, rear & brake lights, indicators, hazard warning lights, reverse light, rear fog light, LED daytime running lights 	•
	Amber flashing beacon mounted on cab	•
	LED random flashing amber warning lights	○
	Rear mounted 12 volt working light	○
CONTROLS & AUDIBLE WARNINGS	High / low speed switch, 2 factory set speed settings between 6.5 and 31mph	•
	Safety seat cut out. Vehicle will not operate unless driver is seated	•
	Emergency isolator	•
	Horn	•
	Automatic audible warning in reverse	•
	Forward audible warning via dash mounted switch (bell)	○
	Automatic audible warning in forward (white noise)	○
	Progressive audible warning system in forward AVAS Acoustic Vehicle Alerting System compliant to UNECE R138	•
EQUIPMENT & FEATURES	High-definition LCD colour display	•
	Battery discharge indicator	•
	Digital speedometer	•
	Odometer	•
	Low level warning lights	•
	Dash mounted lamp to indicate when park brake is applied	•
	12 volt auxiliary socket	•
	Ignition key and steering lock	•
	2 stage deep discharge protection <ul style="list-style-type: none"> • Traction battery low level indicator • Automatic low speed cutback to prevent over discharge 	•

	MODEL	G4-09
TYRES	Tubeless radial 155R13C 90N	•
	Anti puncture treatment	○
	Spare wheel (155R13C 90C) c/w jack & brace	○
	Winter tyres 155/80R13 79Q	○
	Michelin tyre pressure management system	○
TOW HITCH	50mm ball with 7 pin socket	•
	Combined 25mm pin single jaw tow hitch & 50mm ball with 7 pin socket	○
CAB	Polypropylene bumpers	•
	Rear cab window	•
	Central locking	•
	Sliding door windows	•
	ABS glass front and rear screens	•
	Electric front wiper and screen wash	•
	Electric heated front windscreen	•
	Electric heater (700 watt)	•
	Diesel heater	○
	Electric heated drivers seat	○
	Interior and exterior mirrors	•
	Interior light	•
	Glove compartment	•
	MP3 radio with Bluetooth connectivity	•
	USB socket	○
Rear mounted camera with display screen	○	
Cab storage set to include bottle holder and central storage tray	○	
SEATING	Adjustable driver and passenger seats	•
	Padded adjustable headrests	•
	Three-point inertia seat belts	•
BODY	Combined Pick-Up with Electric Leaf Collector	•
	5m extra flexible and anti-abrasive hose 180mm od	•
	Capture netting fitted to rear cage body	•
	Operator harness	•
	Aluminium dropsides and rear tailgate	•
	Resin coated anti-slip plywood deck	•
	25mm mesh cage body	•
	Hydraulic tipping body, complete with aluminium deck (reduces payload capacity by 49kg)	○
	Inter-changeable toolbox (increases payload capacity by 30kg by replacing the leaf collector)	○
Inter-changeable 200L pressure washer (reduces payload capacity by 32kg by replacing the leaf collector)	○	
MISC	1kg dry powder fire extinguisher	○
	Road registered for category N1	○
COLOUR	Chassis: Black, S345 steel, cataphoresis coated, robot welded, powder coating and gap sealing	•
	Cab roof and bonnet: White	•
	Custom colour. Chassis black. Cab roof and bonnet to customer's single colour specification. RAL number to be supplied at time of order	○
	Custom colour. Chassis black. Vinyl wrap cab roof and bonnet to customer's specification	○
	Class 2 hi-visibility reflective band kit	○



BRADSHAW ELECTRIC VEHICLES

New Lane

Stibbington

Peterborough

PE8 6LW

enquiries@bradshawev.com

www.bradshawEV.com

01780 782 621

All data and specifications are in accordance with information available at the time of publication and are subject to change without notice.

Some of the vehicles shown may be fitted with optional equipment or accessories that are available at extra cost.

This brochure supersedes all previous publications.
Issue: April 2022

BRADSHAW
ELECTRIC • VEHICLES